



IHI

Nx

N
series

IHI
MAX-E



Series



9NX-2

- 10 h.p. water cooled diesel engine
- Two speed travel
- Auxiliary hydraulics to front of unit standard
- Standard backfill blade
- Expandable undercarriage from 27.5 to 37.5 inches
- 5'2" digging depth

15NX-2

- 14 h.p. water cooled diesel engine
- Variable displacement piston pumps
- Two speed travel
- Auxiliary hydraulics standard
- Hydraulic pilots controls
- A-F pattern change valve standard
- Standard backfill blade
- Expandable undercarriage from 37.5 to 50 inches
- 7'0" digging depth

25NX-2

- 21.1 h.p. water cooled diesel engine
- Variable displacement piston pumps
- Two speed travel
- Auxiliary hydraulics standard
- Hydraulic pilot controls
- A-F pattern change valve standard
- Rubber or steel tracks
- Standard backfill blade
- 8'3" digging depth

30NX-2

- 23.9 h.p. water cooled diesel engine
- Variable displacement piston pumps
- Two speed travel
- Auxiliary hydraulics standard
- Hydraulic pilot controls
- A-F pattern change valve standard
- Rubber or steel tracks
- Standard backfill blade
- 10'6" digging depth
- Travel pressure boost system



Excellent Digging Force

The high quality and performance of IHI's "NX" series have been secured in the ZERO TAIL SWING mini excavator.

A-F Quick Change Valve

This quick change operating pattern selector allows instant changing from back hoe-style to excavator-style controls with the flip of a switch.

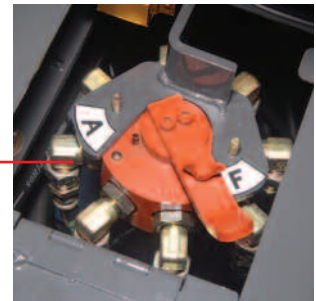

Smoother Operation Exceeding World Standard

Hydraulic pilot Joystick Controls are equipped to offer a high degree of operational responsiveness.





35NX-2

- 26.5 h.p. water cooled diesel engine
- Variable displacement piston pumps
- Two speed travel
- Auxiliary hydraulics standard
- Hydraulic pilot controls
- A-F pattern change valve standard
- Rubber or steel tracks
- Expandable undercarriage from 5 to 6 ft.
- Extendable dipper stick (optional)
- Standard backfill blade
- 11'4" digging depth
- Travel pressure boost system

55NX

- 37.1 h.p. water cooled diesel engine
- Variable displacement piston pumps
- Two speed travel
- Auxiliary hydraulics standard
- Hydraulic pilot controls
- Standard with A-F quick change valve
- Rubber or steel tracks
- Standard backfill blade
- 12'6" digging depth
- Travel pressure boost system

65NX

- 55 h.p. water cooled diesel engine
- Variable displacement piston pump
- Two speed travel
- Auxiliary hydraulics standard
- Hydraulic pilot controls
- A-F pattern change valve standard
- Rubber or steel tracks
- Standard backfill blade
- 12'10" digging depth
- Travel pressure boost system

80NX-3

- 56.3 h.p. water cooled diesel engine
- Variable displacement piston pumps
- Two speed travel
- Auxiliary hydraulics standard
- Hydraulic pilot controls
- A-F pattern change valve standard
- Rubber or steel tracks
- Standard backfill blade
- Standard with fully enclosed heated/air conditioned cabin
- 15'1" digging depth
- Travel pressure boost system

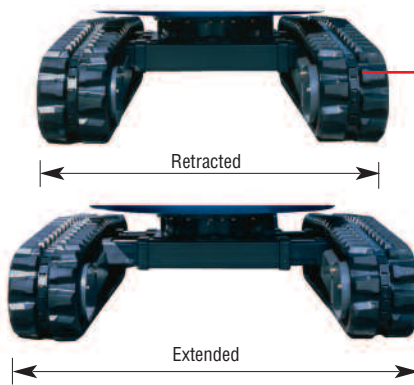

Power and Stability

Side lifting capacity for the 9NX-2, 15NX-2 and 35NX-2 are boosted by a standard expandable undercarriage. The 35NX-2 maximum digging depth is enhanced with an optional extendable dipper stick.



“World Standard” Maintenance

By use of our exclusive arch frame, engine, radiator and battery covers can be fully opened, greatly simplifying inspection and repair.



Series



28N-2

- 21.1 h.p. water cooled diesel engine
- Variable displacement piston pumps
- Two speed travel
- Auxiliary hydraulics standard
- Hydraulic pilot controls
- A-F pattern change valve standard
- Rubber or steel tracks
- Standard backfill blade
- 8'3" digging depth
- Travel pressure boost system

35N-2

- 26.5 h.p. water cooled diesel engine
- Variable displacement piston pumps
- Two speed travel
- Auxiliary hydraulics standard
- Hydraulic pilot controls
- A-F pattern change valve standard
- Rubber or steel tracks
- Standard backfill blade
- 10'4" digging depth
- Travel pressure boost system

55N-2

- 55.5 h.p. water cooled diesel engine
- Variable displacement piston pumps
- Two speed travel
- Auxiliary hydraulics standard
- Hydraulic pilot controls
- A-F pattern change valve standard
- Rubber or steel tracks
- Standard backfill blade
- 12'8" digging depth
- Travel pressure boost system



Maintenance Made Easy

A fully-opening engine cover allows easy access for replacement of filters as well as regular maintenance of the engine.



Smooth Operation

The N Series excavators are equipped standard with hydraulic pilot controls with armrest for extremely smooth operation as well as operator comfort.



Complete Protection

With rugged side protectors and hoses that are run through the arm, the N Series excavators are protected from even the toughest working conditions.



IHI NX-E Series



Available in Single or 3-phase



9NX-E Electric

Interior Workhorse

An orderless, virtually noiseless electric workhorse, ideal for most interior applications that moves well in tight places- including standard door openings.

- 5 h.p. Electric Motor
- Produces no fumes and very little noise
- Two speed travel
- Auxiliary hydraulics to front of unit standard
- Standard backfill blade
- Expandable undercarriage from 27.5 to 37.5 inches
- 5'2" digging depth
- Standard with 100 ft. of power cord

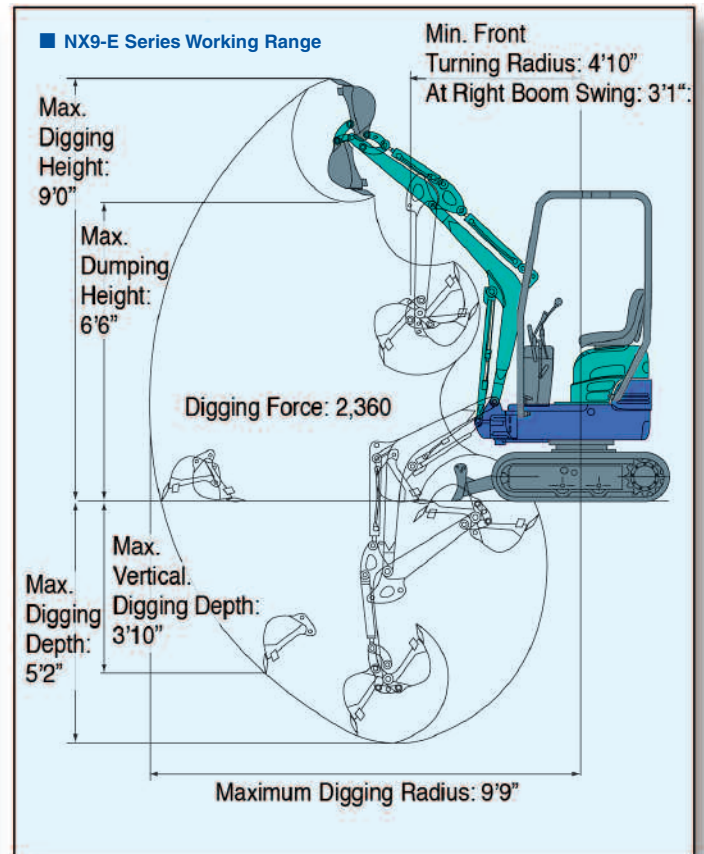
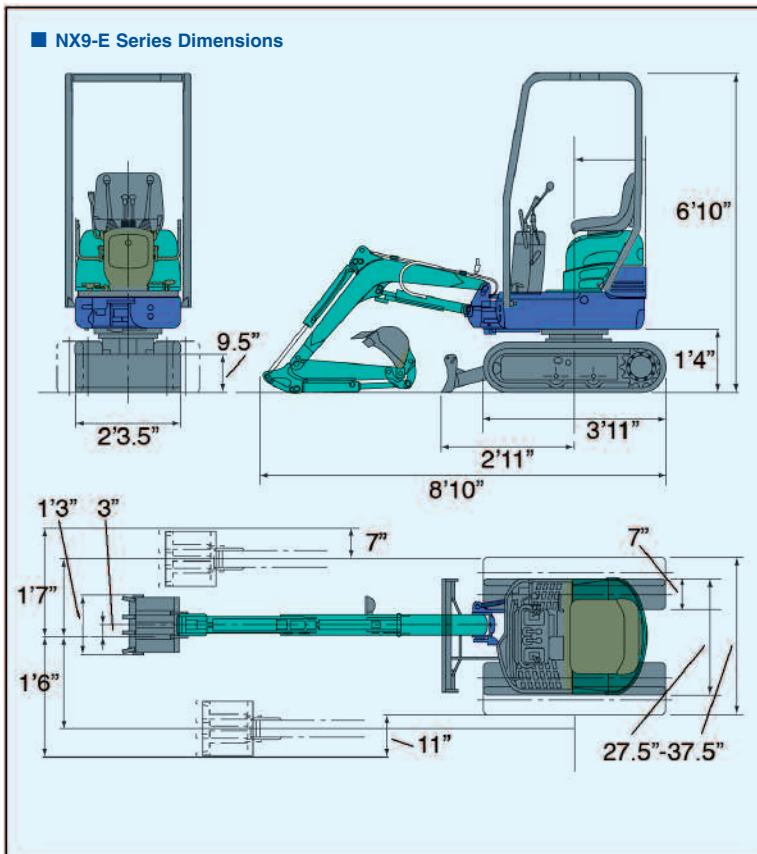

N Series

N Series Dimensions

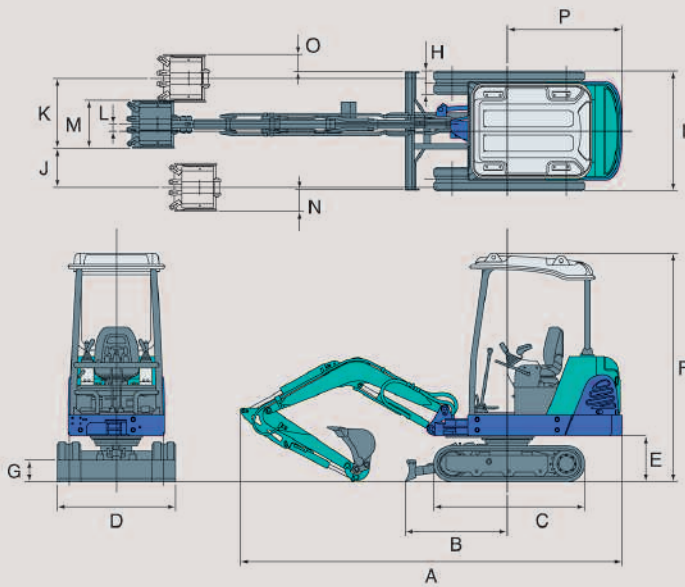

Unit: feet/inches

	A	B	C	D	E	F	G	H	I	J	K	L	M	N	O	P
28N-2	13'8"	4'10"	6'3"	5'1"	1'10"	7'7"	1'2"	12"	5'1"	1'10"	1'6"	2"	1'8"	2"	-2"	4'2"
35N-2	15'11"	5'2"	6'9"	5'1"	1'11"	7'8"	1'2"	12"	5'1"	2'1"	1'8"	2"	2'0"	6"	6"	4'7"
55N-2	18'9"	5'7"	8'2"	6'7"	2'3"	8'2"	1'3"	1'4"	6'7"	2'4"	2'0"	4"	2'3"	2"	-2"	5'1"

Illustration is in proportion to the 28N-2

N Series Working Range

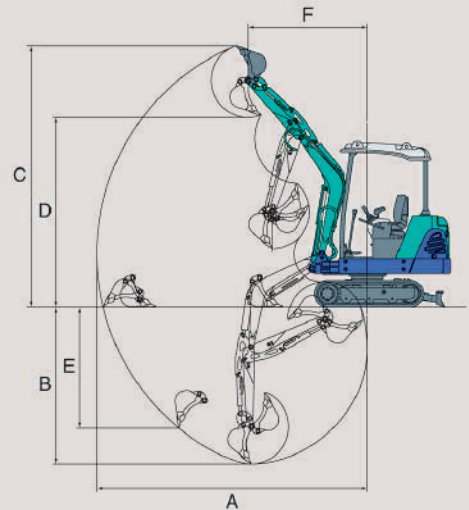

Unit: feet/inches

	Working Range		
	28N-2	35N-2	55N-2*
A Max. Digging Radius	14'2"	16'8"	20'1"
B Max. Digging Depth	8'3"	10'4"	12'8"
C Max. Digging Height	13'3"	15'7"	19'6"
D Max. Dumping Height	9'4"	10'10"	13'6"
E Max. Vert. Digging Depth	6'5"	8'0"	9'8"
F Min. Front Turning Radius	5'11"	6'4"	7'3"
At Right Boom Swing	4'2"	5'6"	5'10"
Bucket Digging Power	5,460 lbs.	7,662 lbs.	11,070 lbs.

* 55J Standard with Cabin

N Series Specifications

Model	28N-2	35N-2	55N-2
• Basic Specifications			
Canopy	4-Post / Cabin	4-Post / Cabin	4-Post / Cabin
Bucket Capacity	2.80 cu. ft.	3.90 cu. ft.	6.40 cu. ft.
Operating Weight	6,189 lbs.	7,759 lbs.	12,733 lbs.
Transport Weight	5,742 lbs.	7,216 lbs.	11,935 lbs.
• Engine			
Model	Yanmar 3TNV76	Yanmar 3TNV84	Yanmar 4TNV94L
Horsepower	21.1 h.p. @ 2,300 rpm	26.5 h.p. @ 2,300 rpm	55.5 h.p. @ 2,400
Fuel Tank Capacity	9.8 gal.	10.6 gal.	19.8 gal.
• Dimensions			
Length	13'8"	15'11"	18'9"
Width	5'1"	5'1"	6'7"
Height	7'7"	7'8"	8'2"
• Hydraulic Equipment			
Pumps	4	4	4
Type-Piston/Gear	2 Piston / 2 Gear	2 Piston / 2 Gear	2 Piston / 2 Gear
Total Flow	20.3 gpm	27.1 gpm	47.4 gpm
Operating Pressure	2,988 psi	2,988 psi	2,988 psi
Auxiliary Flow	12.7 gpm	16.7 gpm	29.7 gpm
• Features			
Travel Speed L/H	1.5 / 2.8 mph	1.7 / 3.0 mph	1.6 / 2.8 mph
Ground Pressure	3.8 psi	4.1 psi	4.4 psi
Swing Speed	10 rpm	8.8 rpm	9.0 rpm
Swing Angle	L50° / R90°	L50° / R90°	L50° / R90°

■ N, NX Series Attachment Options

Quick Coupler System

This quick coupler system has been designed exclusively for the fast and safe change of various attachments mounted on our excavator. This system allows the operator to change out buckets in approximately 25 seconds with no assistance or tools required. The quick coupler system consists of two main parts: the quick coupler with the lock mechanism and the adapter frame. The attachments are locked mechanically. By utilizing this coupler system, one is able to interchange the same buckets on various excavators.

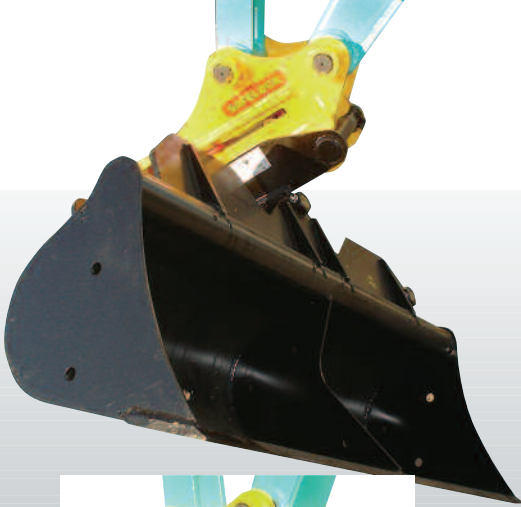

N, NX, and NX-Electric Attachment Options

Model	9NX-2	9NX-E	15NX-2	25NX-2	28N-2	30NX-2	35N-2	35NX-2	55NX	55N-2	65NX	80NX-3
Auger	X	X	X	X	X	X	X	X	X	X	X	X
Hammer	X	X	X	X	X	X	X	X	X	X	X	X
Thumb			X	X	X	X	X	X	X	X	X	X
Special Buckets	X	X	X	X	X	X	X	X	X	X	X	X
Compactor			X	X	X	X	X	X	X	X	X	X
Quick Coupler			X	X	X	X	X	X	X	X	X	X
Grapple			X	X	X	X	X	X	X	X	X	X
Hand Held Tools	X	X	X	X	X	X	X	X	X	X	X	X
Cemetery Bucket			X	X	X	X	X	X	X	X	X	X
Concrete Crusher			X	X	X	X	X	X	X	X	X	X
Rip-N-Pin	X	X	X	X	X	X	X	X	X	X	X	X

80NX with Thumb Attachment Option

IHI Ishikawajima Construction Machinery Co., Ltd.

Distributed by:

Compact Excavator Sales LLC

P.O. Box 667, 400 Production Court, Elizabethtown, KY 42702

Tel.: (800) 538-1447 (270) 737-1447

Sales Fax.: (270) 737-0419

Parts Fax.: (270) 737-1857

www.ihcompactexcavator.com

Authorized Dealer:

