

IHI

COMPACT EXCAVATOR SALES LLC

400 Production Court
Elizabethtown, KY 42701
Phone: 800.538.1447 Fax: 270.737.0419
www.ihices.com



Comfortable operating environment.

A spacious cabin offers a comfortable working space.



New environmentally friendly 3.3L. engine.

Engine compliant with gas emission for EC Stage IIIA and EPA interim Tier4.



Control Valve.

Control valve is positioned on right side of body for easy access and inspection.



Angle crawler frame

The angle crawler frame prevents from pile-up of soil.

Eco-friendliness and Safety

- Engine compliant with gas emission for EC Stage IIIA and EPA Interim Tier4.
- Conforms to the EC low noise regulation.
- Swing parking brake equipped as standard.
- A safety lever locks all operation including traveling and boom swing.

Easy Operation

- Closer distance between bucket and dozer blade.
- Keeps boom brift at minimal levels.
- By optimizing attached geometry, digging performance near the dozer blade has been improved.
- Largest operation space in its class.
- Fuel tank capacity is 22.5 gal.
- Minimum front swing radius is a compact 2'6".

Easy Maintenance

- Sintering metal bush extends greasing interval.
- Aluminum made radiator and oil cooler resist against rusting.
- Segmented boom cylinders hoses for easier replacement.
- Full-opening engine cover for easy maintenance.

Rugged Body

- Embedded boom to prevent damage.
- The engine cover and the side cover are pressed steel and very durable.
- Bucket cylinder hoses are placed inside of arm.

■ Dimensions

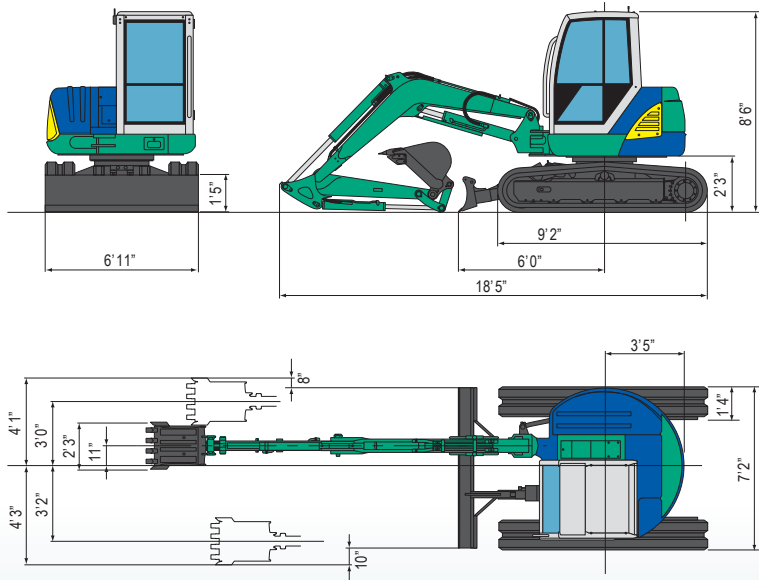

■ Working Range

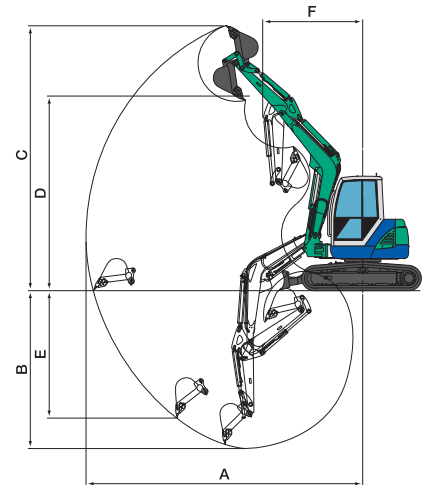

	Cabin or 4 Post
A Max. digging radius	21'4"
B Max. digging depth	12'10"
C Max. digging height	19'0"
D Max. dumping height	13'9"
E Max. vertical digging depth	9'10"
F Min. front turning radius	9'3"
	At right boom swing
	7'0"

※Cabin : Steel Cabin
 ※4Post : Tops Canopy

65VX

Midi Excavator

Standard Bucket Capacity : ISO 7 cu. ft.

Powerful Engine, Outstanding Performance.
6.5 metric ton Zero Midi Excavator.

■ 65VX Specifications

Model	65VX
• Performance	
Bucket capacity	7 cu. ft.
Bucket width	30"
Operating weight : Cabin	14,400
Transportation weight : Cabin	13,950
Swing speed	9.5min ⁻¹
Travel speed (low/high)	1.6/3.2 mph
Gradeability	58% (30°)
Ground pressure	4.4psi
Max. bucket digging force	12,100 lbs
• Engine	
Model	YANMAR 4TNV98
Rated output	55 hp @ 2400
Fuel tank capacity	22.5 gal
• Boom swing system	
Type	Boom offset with hydraulic cylinder
Swing angle (L/R)	50° / 90°
• Hydraulic system	
Pressure	3553 psi
Pump hydraulic flow	39.6 gal / 150L min
Type - Piston/Gear	1 Piston
Auxiliary flow	23.8 gal/min
• Dozer blade	
Size	82" x 17"
Lift above ground / Drop below	14" x 17"



Counterweight
(Standard)



Auxiliary Hydraulic Piping
(Standard)



Steel Shoe
(Optional)

■ Options

• Steel Shoe 16"
• Rubber Pad for Steel Shoe
• Air Conditioner
• Vertical exhaust tailpipe
• Rops canopy (4 Post)

Bucket
12" Bucket with teeth
18" Bucket with teeth
24" Bucket with teeth
30" Bucket with teeth (Standard)
36" Bucket with teeth
60" Ditch Cleaning Bucket (no teeth)

Distributed by **Compact Excavator Sales LLC**

400 Production Court, P.O. Box 667 • Elizabethtown, KY 42702-0667 • Phone: 1-800-538-1447 • Fax: 270-737-0419

www.ihices.com