

80VX

IHI

COMPACT EXCAVATOR SALES LLC

400 Production Court
Elizabethtown, KY 42701
Phone: 800.538.1447 Fax: 270.737.0419
www.ihices.com



Comfortable operating environment.

A wide cabin offering the largest space in its class



New environmentally friendly 3.3L engine.

Engine compliant with EC Stage IIIA and EPA Interim Tier4.

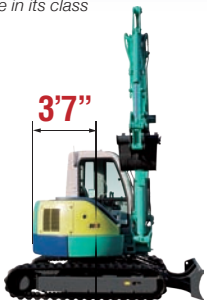

Compact size zero tail swing.

Offers zero tail swing with a 7'2" width, especially beneficial when working in tight spaces.



Large backfill blade.

A large, 20" high backfill blade is equipped as standard. It makes backfilling easier and offers high durability.

Eco-friendliness and Safety

- Engine compliant with EC Stage IIIA and EPA Interim Tier4.
- Conform to the EC low noise regulation.
- Swing parking brake equipped as standard.

Easy Operation

- Closer distance between bucket and backfill blade.
- Joystick lever control enables precision operation.
- Keeps boom drift at minimal levels.
- Largest operation space in its class.
- A large backfill blade makes backfilling easier and offers high durability.
- Rear end swing radius is 3'7".

Easy Maintenance

- Sintering metal bush extends greasing interval.
- Aluminum made radiator and oil cooler resist rusting.
- Segmented boom cylinder hoses for easier replacement.
- Large engine cover for easy maintenance.

Rugged Body

- The engine cover and the side cover are pressed steel and very rugged.
- Bucket cylinder hoses are placed inside the arm.

■ Dimensions

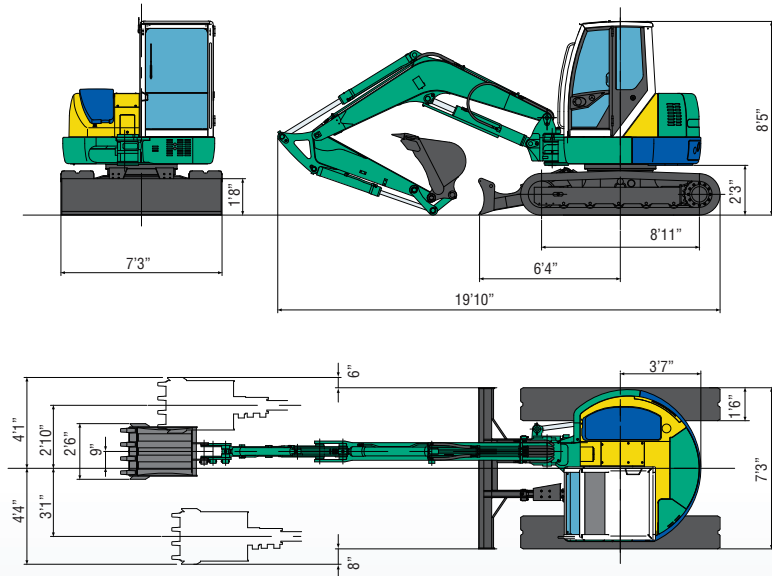

■ Working Range

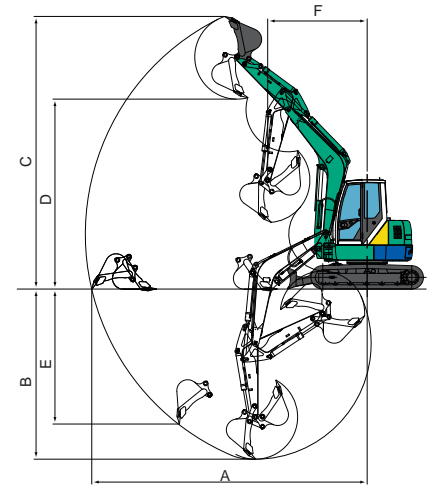

	Cabin
A Max. digging radius	23'4"
B Max. digging depth	15'1"
C Max. digging height	22'9"
D Max. dumping height	16'0"
E Max. vertical digging depth	11'9"
F Min. front turning radius	8'5"
At right boom swing	7'3"



80VX

Midi Excavator

Standard Bucket Capacity: ISO 8.8 cu. ft.

*Smooth and Powerful Operation.
8.0 metric ton Zero Tail Swing Midi Excavator*

■ 80VX Specifications

Model	80VX
• Performance	
Bucket capacity	8.8 cuft
Bucket width	30"
Operating weight : Cabin	18100 lbs
Transportation weight : Cabin	17635 lbs
Swing speed	9.2 mph
Travel speed (low/high)	1.6 mph / 2.7 mph
Gradeability	30°
Ground pressure	5.2 psi
Max.bucket digging force	14730 lbs
• Engine	
Model	YANMAR 4TNV98
Rated output	58.7 hp / 2100 rpm
Fuel tank capacity	22.5 gal
• Boom swing system	
Type	Boom offset with hydraulic cylinder
Swing angle (L/R)	50° / 90°
• Hydraulic system	
Pressure	3550 psi
Pump hydraulic flow	18.9 gal/ min x 2 + 14.0 gal/ min
Type-Piston / Gear	2 Piston + 2 Gear
Auxiliary Flow	18.9 gal
• Backfill blade	
Size	87" x 20"
Lift above ground / Drop below ground	17.1" / 16.5"



Additional Counterweight
(Standard Equipment)



Steel Shoe
(Optional)

■ Options

• Buckets	
12"	
18"	
24"	
30"	
36"	
48" Ditch Cleaning Bucket	
60" Ditch Cleaning Bucket	
60" Hydraulic Swivel Bucket	
• Steel Tracks	
• Hydraulic Thumb	
• Quick Coupler	