

35W

IHI

COMPACT EXCAVATOR SALES LLC

400 Production Court
Elizabethtown, KY 42701
Phone: 800.538.1447 Fax: 270.737.0419
www.ihices.com



Full-opening cover.

The engine cover and right side cover all can easily be fully opened.



Larger engine adopted.

Engine compliant for EC Stage IIIA and EPA Interim Tier4.



Accumulator

The accumulator is installed to depressurize auxiliary line and lower attachments in emergency.



Large Traction pedals

The large traction pedals are equipped as standard.

Eco-friendliness and Safety

- Engine compliant for EC Stage IIIA and EPA Tier4.
- Conform to the EC low noise regulation.
- Swing parking brake equipped as standard.
- The accumulator is installed as to depressurize auxiliary line and lower attachments in emergency.

Easy Operation

- Joystick lever control enables precision operation.
- Largest operation space in its class.
- A large backfill blade makes backfilling easier and offers high durability.
- Travel speed selector switches equipped in two locations. (On backfill lever and the left console box.)
- The foot space extended. (10% wider than N2.)

Easy Maintenance

- Sintering metal bush extends greasing interval.
- Aluminum radiator and oil cooler resist rusting.
- Segmented boom cylinder hoses for easier replacement.
- Full-opening engine cover for easy maintenance.
- The radiator protective net is equipped as standard.

Rugged Body

- Embedded boom lamp to prevent damage.
- The engine cover and the side cover are pressed steel and very rugged.
- Bucket cylinder hoses are placed inside the arm.
- Cast Iron large side guard and counterweight.
- Arm link pin fixed by castle nut.

■ Dimensions

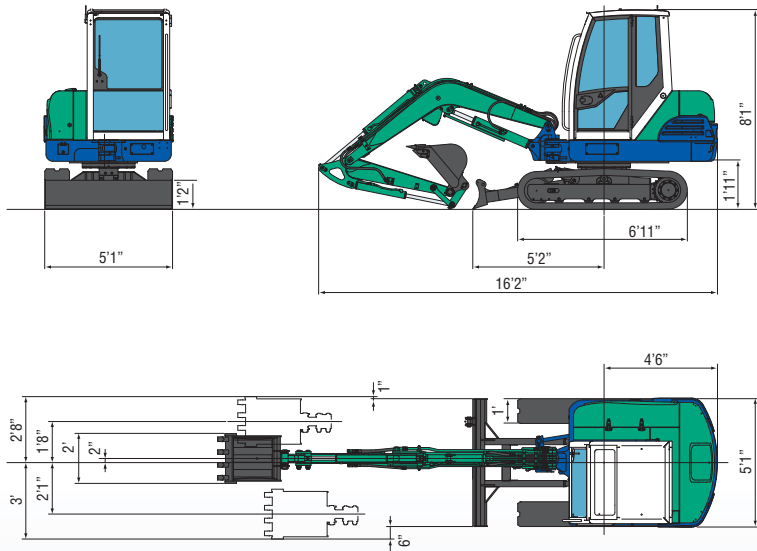

■ Working Range

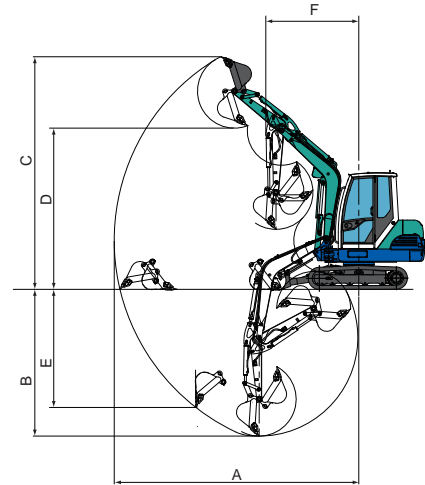

	Cabin
A Max. digging radius	16'8"
B Max. digging depth	10'4"
C Max. digging height	16'2"
D Max. dumping height	11'
E Max. vertical digging depth	8'
F Min. front turning radius	6'4"
At right boom swing	5'



35N

Mini Excavator

Standard Bucket Capacity: ISO 3.9 cu. ft.

*Outstanding Stability, Robust Design.
3.5 metric ton Conventional Type Mini.*

■ 35N3 Specifications

Model	35N3
• Performance	
Bucket capacity	3.9 cuft
Bucket width	24"
Operating weight : Cabin (4 post)	7979 lbs (7759 lbs)
Transportation weight : Cabin (4 post)	7439 lbs (7219 lbs)
Swing speed	10 mph
Travel speed (low/high)	1.7/3 mph
Gradeability	30°
Ground pressure	4.1 psi
Max.bucket digging force	7662 lbs
• Engine	
Model	YANMAR 3TNV88
Rated output	26.7 hp/2300 rpm
Fuel tank capacity	13 gal
• Boom swing system	
Type	Boom offset with hydraulic cylinder
Swing angle (L/R)	50° / 90°
• Hydraulic system	
Pressure	2987 psi
Pump hydraulic flow	10.6 gal/ min x2 + 6.5 gal/ min
Type Piston / Gear	2 Piston / 2 Gear
Auxiliary Flow	16.7 gal
• Backfill blade	
Size	61" × 14"
Lift above ground / Drop below ground	15"/ 18"



4 Post Canopy

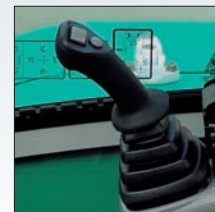

Proportional Control Valve

■ Options

• Bucket
12"
18"
24"
36"
48" Ditch Cleaning Bucket
48" Hydraulic Swivel Bucket
• Steel Tracks
• Steel Cab
• Hydraulic Thumb
• Quick Coupler