

35VX

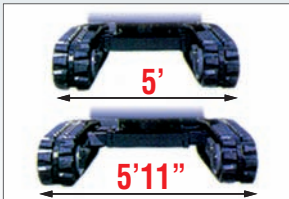

400 Production Court
Elizabethtown, KY 42701
Phone: 800.538.1447 Fax: 270.737.0419
www.ihices.com



Wide Spanner

Spanner function (5' ↔ 5'11") has been equipped as standard. The wide span allows improved stability while allowing entry into tight spaces.



Closer distance between bucket and backfill blade.

By optimizing attachment geometry, digging performance near the backfill blade has been improved.



New environmentally friendly engine.

Clean engine compliant with exhaust emission for EC Stage IIIA and EPA Interim Tier4.



Full-opening cover.

The engine cover, right side cover all can easily be fully opened.

Eco-friendliness and Safety

- Engine compliant for EC Stage IIIA and EPA Tier4.
- Conform to the EC low noise regulation.
- 4 post canopy (ROPS&TOPS) equipped as standard.
- Swing parking brake equipped as standard.

Easy Operation

- Closer distance between bucket and backfill blade.
- Joystick lever control enables precision operation.
- Keeps boom drift at minimal levels.
- Largest operation space in its class.
- A large backfill blade makes backfilling easier and offers high durability.
- Spanner function (5' ↔ 5'11") has been equipped as standard.

Easy Maintenance

- Sintering metal bush extends greasing interval.
- Aluminum radiator and oil cooler resist rusting
- Segmented boom cylinder hoses for easier replacement.
- Full-opening engine cover for easy maintenance.

Rugged Body

- Embedded boom lamp to prevent damage.
- The engine cover and the side cover are pressed steel and very rugged.
- Bucket cylinder hoses are placed inside the arm.

■ Dimensions

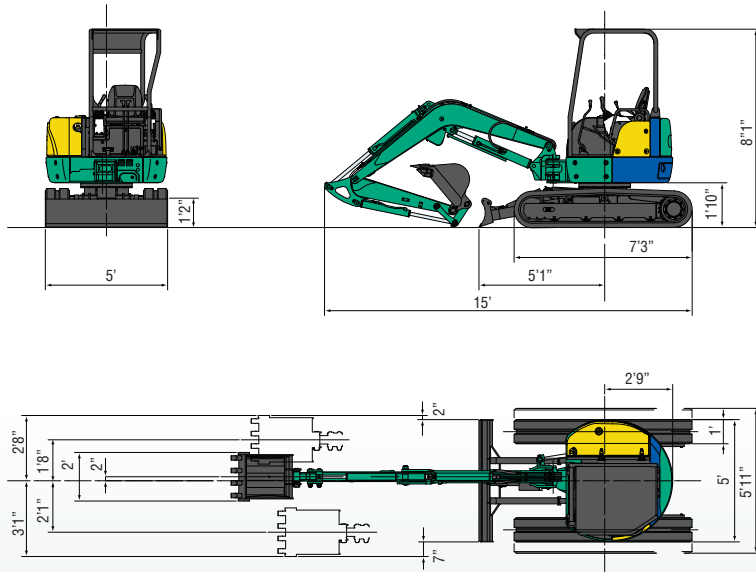

■ Working Range

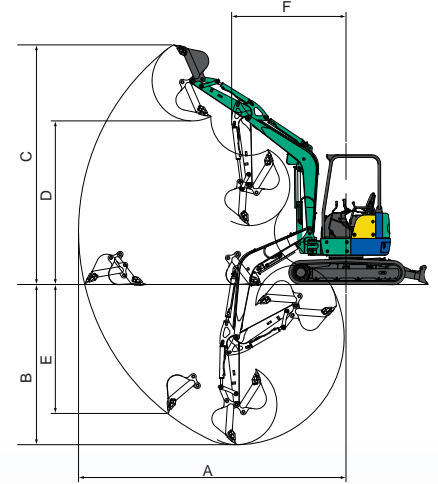

| | 4post or Cabin |
|-------------------------------|----------------|
| A Max. digging radius | 17'9" |
| B Max. digging depth | 11'4" |
| C Max. digging height | 16'2" |
| D Max. dumping height | 11'1" |
| E Max. vertical digging depth | 9'8" |
| F Min. front turning radius | 7'2" |
| At right boom swing | 5'8" |



35VX

Mini Excavator

Standard Bucket Capacity: ISO 3.9 cu. ft.

*Unrivalled 5'-5'11" Variable Width.
Stability and Transportability.*

■ 35VX2 Specifications

| | |
|---------------------------------------|-------------------------------------|
| Model | 35VX |
| • Performance | |
| Bucket capacity | 3.9 cuft |
| Bucket width | 24" |
| Operating weight : 4post (Cabin) | 7507 lbs (7727 lbs) |
| Transportation weight : 4post (Cabin) | 7341 lbs (7562 lbs) |
| Swing speed | 8.8 mph |
| Travel speed (low/high) | 1.7 mph / 3 mph |
| Gradeability | 30° |
| Ground pressure | 4.2 psi |
| Max.bucket digging force | 7688 lbs |
| • Engine | |
| Model | YANMAR 3TNV88 |
| Rated output | 27.6 hp / 2300 rpm |
| Fuel tank capacity | 9.2 gal |
| • Boom swing system | |
| Type | Boom offset with hydraulic cylinder |
| Swing angle (L/R) | 50° / 90° |
| • Hydraulic system | |
| Pressure | 3000 psi |
| Pump hydraulic flow | 10.6 gal/ min x 2 + 6.5 gal /min |
| Type-Piston/ Gear | 2 Piston + 2 Gear |
| Auxiliary Flow | 16.6 gal |
| • Backfill blade | |
| Size | 60" x 14" |
| Lift above ground / Drop below ground | 14.6" / 15" |

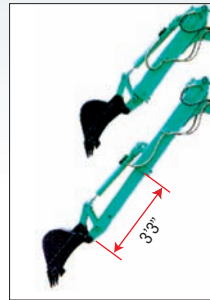

Slide Arm



Steel Shoe



Steel Cabin

■ Options

| |
|-----------------------------|
| • Buckets |
| 12" |
| 18" |
| 24" |
| 48" Ditch Cleaning Bucket |
| 48" Hydraulic Swivel Bucket |
| • Steel Cabin |
| • Steel Tracks |
| • Slide Arm |
| • Hydraulic Thumb |
| • Quick Coupler |